

# METALMASTER



Edition : 1.0  
Date: (9/25)

## Instruction Manual

# ENGLISH WHEEL EWHD-100

Order Code: (S2256)

## MACHINE DETAILS

MACHINE.	English Wheel
MODEL NO.	EWHD-100
SERIAL NO.	
DATE OF MANF.	

Imported by

Australia



[www.machineryhouse.com.au](http://www.machineryhouse.com.au)

New Zealand



[www.machineryhouse.co.nz](http://www.machineryhouse.co.nz)

### NOTE:

*This manual is only for your reference. At the time of the compiling of this manual every effort to be exact with the instructions, specifications, drawings, and photographs of the machine was taken. Owing to the continuous improvement of the METALMASTER machine, changes may be made at any time without obligation or notice. Please ensure the local voltage is the same as listed on the specification plate before operating any electric machine.*

### SAFETY SYMBOLS:

*The purpose of safety symbols is to attract your attention to possible hazardous conditions*



**WARNING** Indicates a potentially hazardous situation causing injury or death



**CAUTION** Indicates an alert against unsafe practices.

**Note:** Used to alert the user to useful information

### NOTE:

*In order to see the type and model of the machine, please see the specification plate. Usually found on the back of the machine. See example (Fig.1)*

Fig.1

	
<b>PRODUCT SPECIFICATIONS</b>	
Model: EWHD-100	Nett Weight: 490kg
Capacity: 1.6mm MS	MFG Date:
Serial No:	<input type="text"/>
Imported by <a href="http://www.machineryhouse.com.au">www.machineryhouse.com.au</a>	Made in China <a href="http://www.machineryhouse.co.nz">www.machineryhouse.co.nz</a>

**CONTENTS:**

1. GENERAL MACHINE INFORMATION	
1.1 Specifications .....	4
1.2 Included Accessories.....	4
1.3 Identification .....	5
2. IMPORTANT INFORMATION	
2.1 General Metalworking Machine Safety.....	6
2.2 Specific Safety For English Wheels .....	9
3 SETUP	
3.1 Unpacking.....	10
3.2 Clean Up .....	10
3.3 Site Preparation .....	10
3.4 Lifting Instructions .....	10
3.5 Assembly .....	11
4. OPERATION	
4.1 Operation Overview .....	12
4.2 Selecting The Lower Wheel .....	13
4.3 Adjusting The Lower Wheel .....	13
4.4 Tracking Patterns .....	15
5. MAINTENANCE	
5.1 Schedule .....	17
5.2 Troubleshooting .....	17
Spare Parts.....	18

## 1.1 SPECIFICATIONS

Order Code	S2256
<b>MODEL</b>	<b>EWHD-100</b>
Capacity Mild Steel (mm)	1.6
Capacity Aluminium (mm)	3.2
Throat Capacity (mm)	1016
Upper Wheel (Ø x mm)	Ø254 x 76.2
Lower Anvil - Radius (mm)	flat, 50.8, 101.6, 152.4, 203.2, 304.8, 609.6, 914.4, 1219
Working Height (mm)	1200
Weight (kg)	490

## 1.2 ACCESSORIES

Quick release anvil cradle for rapid and easy panel removal

8 lower anvils (all 76.2mm wide) in the following radius:

- 50.8 mm,
- 101.6 mm,
- 152.4 mm,
- 203.2 mm,
- 304.8 mm,
- 609.6 mm,
- 914.4 mm,
- 1219.2 mm.



### **WARNING!**

*The machine is the sole responsibility of the owner for its safe use. This responsibility includes but is not limited to proper installation in a safe environment, personnel training, proper inspection and maintenance, manual availability and comprehension. The manufacturer will not be held liable for injury or property damage from negligence, improper training, machine modifications or misuse.*

## 1.3 IDENTIFICATION

Become familiar with the names and locations of the controls and features shown below to better understand the instructions when mentioned later in this manual.

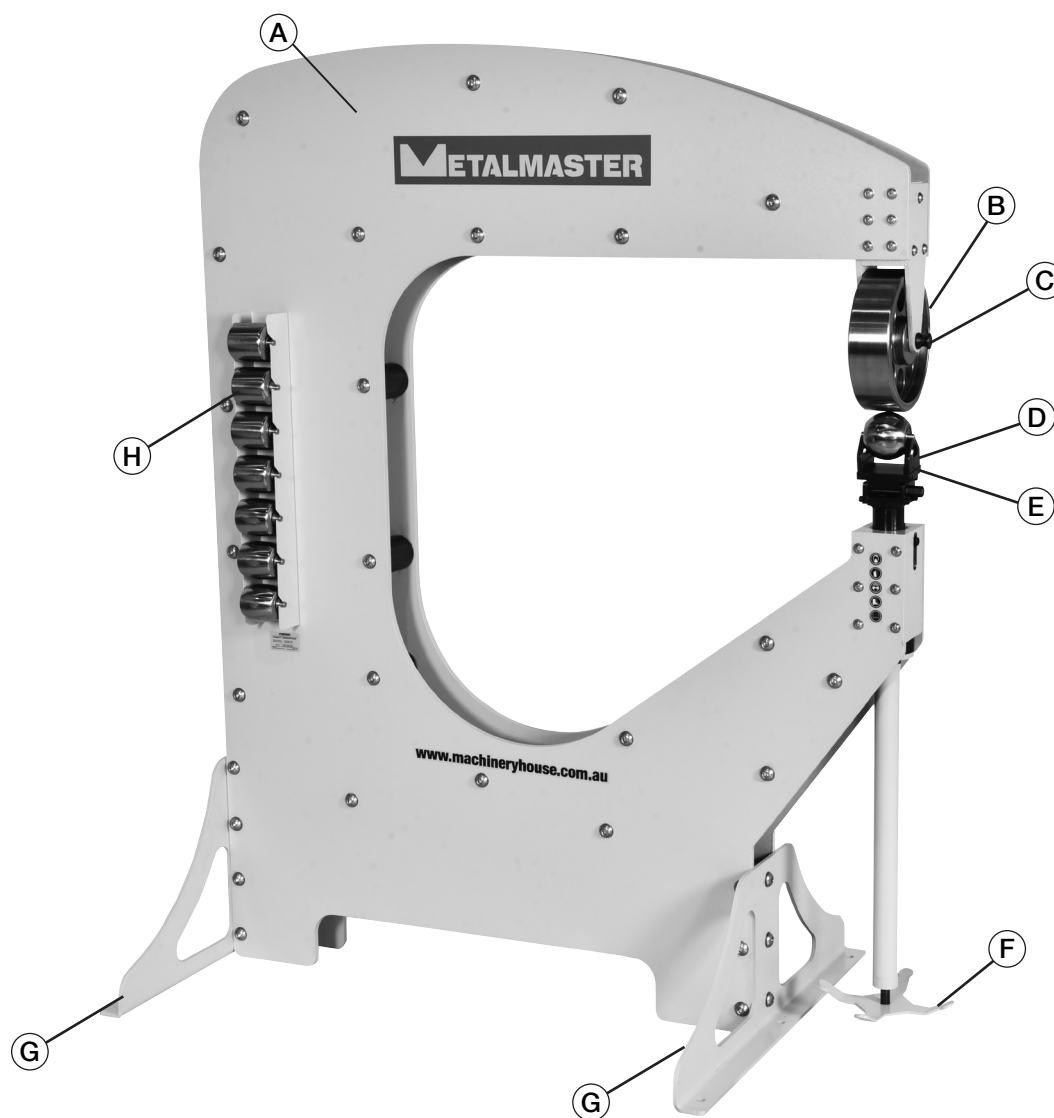

<b>A</b>	Frame	<b>E</b>	Quick Release Lower Wheel Cradle
<b>B</b>	Upper Wheel Bracket	<b>F</b>	Adjusting Hand Wheel
<b>C</b>	Upper Wheel Axle	<b>G</b>	Wide Feet with Anchor Holes
<b>D</b>	Lower Wheel Cradle	<b>H</b>	Lower Wheel Storage

## 2. IMPORTANT INFORMATION

### 2.1 GENERAL METALWORKING MACHINE SAFETY

DO NOT use this machine unless you have read this manual or have been instructed in the use of this machine in its safe use and operation.



## WARNING!

This manual provides safety instructions on the proper setup, operation, maintenance and service of this machine. Save this manual, refer to it often, and use it to instruct other operators.

Failure to read, understand and follow the instructions in this manual may result in fire or serious personal injury—including amputation, electrocution, or death.

The owner of this machine is solely responsible for its safe use. This responsibility includes, but is not limited to proper installation in a safe environment, personnel training and authorization to use, proper inspection and maintenance, manual availability and comprehension of the application of the safety devices, integrity and the use of personal protective equipment.

The manufacturer will not be held liable for injury or property damage from negligence, improper training, machine modifications or misuse.



- ✓ Always wear safety glasses or goggles.
- ✓ Wear appropriate safety footwear.
- ✓ Wear respiratory protection where required.
- ✓ Gloves should never be worn while operating the machine, and only worn when handling the workpiece.
- ✓ Wear hearing protection in areas where sounds are > 85 dBA. or if you have trouble hearing someone speak from one metre (three feet) away. Noise levels from the machine may be hazardous.
- ✓ DISCONNECT THE MACHINE FROM POWER when making adjustments or servicing.
- ✓ Check and adjust all safety devices before each job.
- ✓ Ensure that guards are in position and in good working condition before operating.
- ✓ Ensure that all stationary equipment is anchored securely to the floor.
- ✓ Ensure all machines have a start/stop button within easy reach of the operator.
- ✓ Each machine should have only one operator at a time. However, everyone should know how to stop the machine in an emergency.

## 2.1 GENERAL SAFETY REQUIREMENTS CONT.

- ✓ Ensure that keys and adjusting wrenches have been removed from the machine before turning on the power. Appropriate storage for tooling should be provided.
- ✓ Ensure that all cutting tools and blades are clean and sharp. They should be able to cut freely without being forced.
- ✓ Stop the machine before measuring, cleaning or making any adjustments.
- ✓ Wait until the machine has stopped running to clear cuttings with a vacuum, brush or rake.
- ✓ Keep hands away from the cutting head and all moving parts.
- ✓ Avoid awkward operations and hand positions. A sudden slip could cause the hand to move into the cutting tool or blade.
- ✓ Return all portable tooling to their proper storage place after use.
- ✓ Clean all tools after use.
- ✓ Keep work area clean. Floors should be level and have a non-slip surface.
- ✓ Use good lighting so that the work piece, cutting blades, and machine controls can be seen clearly. Position any shade lighting sources so that they do not cause any glare or reflections.
- ✓ Ensure there is enough room around the machine to do the job safely.
- ✓ Obtain first aid immediately for all injuries.
- ✓ Understand that the health and fire hazards can vary from material to material. Make sure all appropriate precautions are taken.
- ✓ Clean machines and the surrounding area when the operation is finished.
- ✓ Use proper lock out procedures when servicing or cleaning the machines or power tools.

### DO NOT

- ✗ Do not distract an operator. Horseplay can lead to injuries and should be strictly prohibited.
- ✗ Do not wear loose clothing, gloves, neckties, rings, bracelets or other jewellery that can become entangled in moving parts. Confine long hair.
- ✗ Do not handle cuttings by hand because they are very sharp. Do not free a stalled cutter without turning the power off first. Do not clean hands with cutting fluids.
- ✗ Do not use rags or wear gloves near moving parts of machines.
- ✗ Do not use compressed air to blow debris from machines or to clean dirt from clothes.
- ✗ Do not force the machine. It will do the job safer and better at the rate for which it was designed.

## 2.1 GENERAL SAFETY REQUIREMENTS CONT.

HAZARDS ASSOCIATED WITH MACHINES include, but are not limited to:

- Being struck by ejected parts of the machinery
- Being struck by material ejected from the machinery
- Contact or entanglement with the machinery
- Contact or entanglement with any material in motion

Health Hazards (other than physical injury caused by moving parts)

- Chemicals hazards that can irritate, burn, or pass through the skin
- Airborne items that can be inhaled, such as oil mist, metal fumes, solvents, and dust
- Heat, noise, and vibration
- Ionizing or non-ionizing radiation (X-ray, lasers, etc.)
- Biological contamination and waste
- Soft tissue injuries (for example, to the hands, arms, shoulders, back, or neck) resulting from repetitive motion, awkward posture, extended lifting, and pressure grip)

Other Hazards

- Slips and falls from and around machinery during maintenance
- Unstable equipment that is not secured against falling over
- Safe access to/from machines (access, egress)
- Fire or explosion
- Pressure injection injuries from the release of fluids and gases under high pressure
- Electrical Hazards, such as electrocution from faulty or ungrounded electrical components
- Environment in which the machine is used (in a machine shop, or on a work site)



### **WARNING!**

*The machine is the sole responsibility of the owner for its safe use. This responsibility includes but is not limited to proper installation in a safe environment, personnel training, proper inspection and maintenance, manual availability and comprehension. The manufacturer will not be held liable for injury or property damage from negligence, improper training, machine modifications or misuse.*



### **WARNING!**

*Machines are safeguarded to protect the operator from injury or death with the placement of guards. Machines must not be operated with the guards removed or damaged.*

## 2.2 SPECIFIC SAFETY FOR ENGLISH WHEELS

**DO NOT use this machine unless you have been instructed in its safe use and operation and have read and understood this manual.**



*Safety glasses must be worn at all times in work areas.*



*Close fitting protective clothing or overalls are encouraged*



*Appropriate protective footwear with substantial uppers must be worn.*



*Rings and jewellery must NOT be worn in the workshop*



*Gloves should be worn when handling the work piece*



*Ear protection should be used in loud and noisy conditions*

### PRE-OPERATIONAL SAFETY CHECKS

1. Ensure you are familiar with the operation of the English Wheel
2. Check for any damage or parts missing
3. The area around the machine must be clean and free of trip hazards.
4. Any forming die must be inspected for safe use i.e. no cracks.
5. Ensure safety glasses or goggles are available and are worn by all persons in the vicinity.
6. Any test piece, project or material (work piece) to be worked must be of an appropriate thickness and safe to use on this equipment.
7. Faulty equipment must not be used. Immediately check suspect machinery.

### OPERATIONAL SAFETY CHECKS

1. Place your test piece, project or material (work piece) securely between the top and bottom dies.
2. Do not over reach. Maintain a balanced stance at all times, so that you do not fall or lean against the machine.
3. Use the English Wheel by moving the workpiece in a forward and back action, to slowly work the material.
4. Keep hands and fingers away from the dies.
5. Wear leather gloves when handling the work piece.
6. Use the right tool. Do not force a die set to do a job that it was not designed to do.
7. Give your work undivided attention. Looking around, carrying on a conversation and “horse-play” are careless acts that can result in serious injury.
8. DO NOT apply excessive force to the English Wheel.

### AFTER OPERATION COMPLETED

1. Clean the machine and place any tools and equipment in the appropriate storage area.
2. Place all scrap or waste in the appropriate bin.

### POTENTIAL HAZARDS

- Beware of high forces applied
- Pinch and squash
- Eye injuries – flying or shattering objects
- Laceration injuries

### 3 SET-UP

#### 3.1 UNPACKING

This machine was carefully packaged for safe transport. When unpacking, separate all enclosed items from packaging materials and inspect them for shipping damage. If items are damaged, please contact your distributor.

**NOTE: Save all the packaging materials until you are completely satisfied with the machine and have resolved any issues with the distributor, or the shipping agent.**

When unpacking, check the packing list to make sure that all parts shown are included. If any parts are missing or broken, please contact your distributor.

#### 3.2 CLEAN - UP

The unpainted surfaces of the machine have been coated with a waxy oil to protect them from corrosion during shipment. Remove the protective coating with a solvent cleaner or a citrus based degreaser.

Optimum performance from your machine will be achieved when you clean all moving parts or sliding contact surfaces that are coated with rust preventive products.

It is advised to avoid chlorine based solvents, such as acetone or brake parts cleaner, as they will damage painted surfaces and strip metal should they come in contact. Always follow the manufacturer's instructions when using any type of cleaning product.

#### 3.3 SITE PREPARATION

When selecting the site for the machine, consider the largest size of work piece that will be processed through the machine and provide enough space around the machine for operating the machine safely. Consideration should be given to the installation of auxiliary equipment. Leave enough space around the machine to open or remove doors/covers as required for the maintenance and service as described in this manual.

It is recommended that the machine is anchored to the floor to prevent tipping or shifting. It also reduces vibration that may occur during operation.

#### 3.4 LIFTING INSTRUCTIONS



*This machine is very heavy.*

***Serious personal injury may occur if safe moving methods are not followed. To be safe, you will need assistance from another person when moving the shipping crate and removing the machine from the crate.***



On the day that the machine arrives, make sure that there is assistance available to unload the machine from the vehicle. Ensure access to the chosen site is clear and that doors and ceilings are sufficiently high and wide enough to receive the machine.



#### **CAUTION!**

***This machine may not appear to be heavy, but damage to the back or legs can occur if lifting practices are not followed. When lifting bend the knees and keep the back straight.***

## 3.5 ASSEMBLY

The machine must be fully assembled before it can be operated. First clean any parts that are coated in rust preventative to ensure the assembly process can proceed smoothly.

### To Attach the Feet:

1. Lay out on a clear space close to where the machine is to be placed all the parts of the stand.
2. Locate the two wide feet anchor plates (30#) and attach with the M16 x 30 round head hex screws and flat washes. (Fig. 3.1)

**Note:** Ensure that the angle portion that has the floor mounting bolt holes face outward.

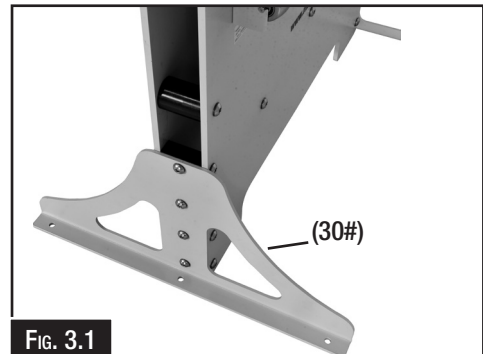

FIG. 3.1

### Lower Wheel Storage:

Locate the lower wheel rack (13#) and attach it to the side of the main frame using the 2 off M8 x 20mm screws, making sure that the slots in the storage unit faces upwards. (Fig. 3.2)

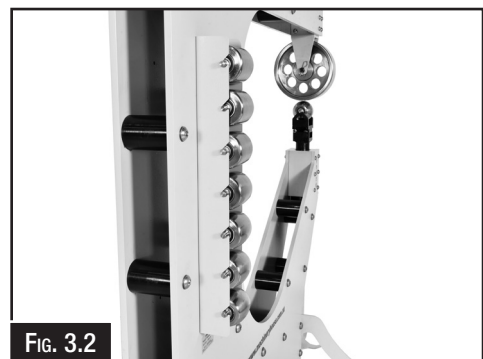

FIG. 3.2

### Assemble Lower Roller Adjustment:

1. Attach the hand wheel (15#) onto the squared end of the lower wheel adjustment screw using the M6 x 10mm screw and flat washers. (39#) (Fig. 3.3)
2. Then rotate to check that the adjustment raises or lowers the lower wheel saddle.

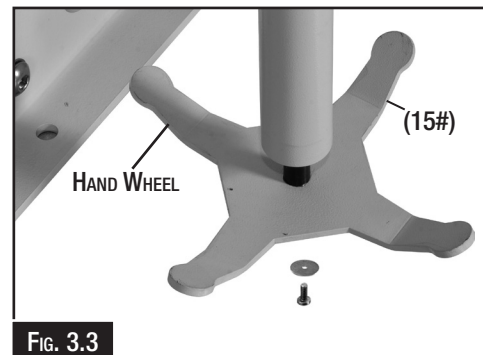

FIG. 3.3

### Assemble Upper Roller:

1. Place the large upper wheel in upper wheel bracket, then install the wheel axle. (Fig. 3.4)
2. Install the spring clip in the upper wheel axle to secure upper wheel in the top roller bracket. (Fig. 3.4)

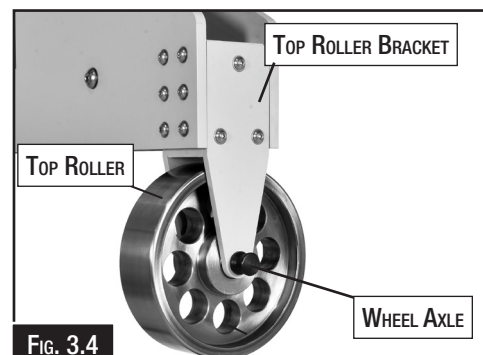

FIG. 3.4



## WARNING!

**DO NOT** operate any machine before it is fully assembled and all the safety guards have been fitted and secured. Failure to do so may cause death or severe injury.

## 4. OPERATION

This machine may perform many types of operations that are beyond the scope of this manual. Many of these operations may be dangerous or deadly if performed incorrectly.

The instructions in this section are written with the understanding that the operator has the necessary knowledge and skills to operate this machine. If at any time you are experiencing difficulties performing any operation, stop using the machine!

If you are an inexperienced operator, we strongly recommend that you read books, trade articles, or seek training from an experienced operator before performing any unfamiliar operations. **Above all, your safety should come first!**

### 4.1 OPERATION OVERVIEW

This overview purpose is to provide a novice machine operator with a basic understanding of how the machine is used during operation, and so that if the machine controls or components are mentioned later in this manual, it will be easy to understand. The overview is not intended to be an instructional guide and is only generic in nature.

To learn more about the specific operation, read this entire manual and seek additional training from an experienced machine operator. Another source of information may be found in videos on websites or by reading trade magazines.

A typical operation involves the following steps:

1. The operator must put on safety protection such as safety glasses, leather gloves, and steel-toed shoes.
2. The work piece should have any sharp edges removed with a deburring tool.
3. The work piece and wheels must be cleaned thoroughly and all abrasive particles removed.
4. Select the lower wheel with the least amount of radius and then place it into the lower wheel saddle.
5. Adjust the lower wheel handle until the distance between the bottom of the upper wheel and top of the lower wheel is about 12mm.
6. Mark on the work piece approximately a 25mm frame around the edges then place the work piece between the wheels.
7. Rotate the bottom wheel adjustment hand wheel until there is just enough pressure to prevent workpiece from skipping or slipping,
8. Move the work piece back and forth between wheels using one of the tracking patterns (see Tracking Patterns on Page 15), rolling it up to an edge, rotating it slightly, then pulling it back.
9. When the workpiece no longer stretches, use the bottom wheel adjustment hand wheel to slightly increase the pressure.
10. When the workpiece no longer moves through the wheels, then change the lower wheel to the next smallest radius and repeat until the curve required is obtained.

**NOTE: PRACTICE AND PATIENCE.** *An English wheel is a simple tool that is easy to start to use however, it is the type of tool that requires experience to master.*

*When an operator keeps in mind a few safety considerations as noted in the front of the manual they can create and form metal to almost any shape.*

## 4.2 SELECTING THE LOWER WHEEL

When choosing the lower wheel choose one that will produce the contour that the work piece requires

Domed lower wheels create tighter curves. Flat areas at the center of the lower wheel range from 3mm to 12mm wide.

The wider the flat area is, the wider the track will be produced on the work piece.

**NOTE: For dimensions of the lower wheel see diagram on page 14**

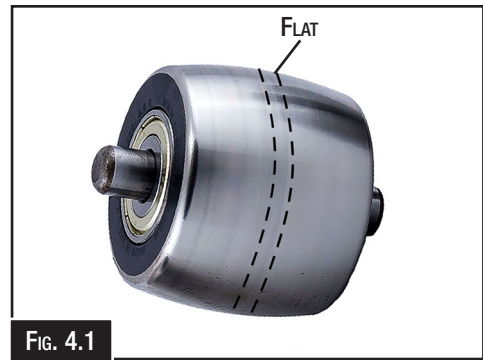

FIG. 4.1

To select the correct bottom roller (or anvil die) for an English wheel, choose a die with a crown (curvature) that closely matches the desired final shape of the panel. If you want to form a compound curve, use a die with a tighter, more aggressive curvature. For flatter shapes, a flatter, less crowned die is appropriate.

### Steps for Selecting a Bottom Roller:

1. **Assess the panel's desired curvature:**

Look at the shape you want to create. Do you need to form a wide, gentle curve, or a tighter, more pronounced double curvature?

2. **Match the die's crown to the desired shape:**

For a low-crown, large-radius curve: Use a flatter, lower-crowned die. For a high-crown, compound curve: Use a tighter, higher-crowned die.

3. **Understand the impact of the die's crown:**

A flatter die creates less aggressive stretch and a gentler overall shape. A more rounded (higher-crowned) die provides a smaller contact area but creates more stretch and a tighter curve in the metal.

4. **Consider using multiple dies:**

You may need to use a series of different bottom dies during the metal-forming process to achieve a complex shape.

5. **Test the setup:**

Always perform test runs on scrap material to confirm the bottom roller is creating the intended curvature before working on your final piece.

## 4.3 ADJUSTING THE LOWER WHEEL

To adjust the lower wheel on an English wheel, locate the bracket height handle or tension adjustment mechanism, which is the height hex nut adjustment and turn it to raise or lower the lower wheel. You want a gap just slightly larger than the metal's thickness for a loose pinch, which creates a better working distance and prevents unwanted creasing, though it may require more passes to achieve the desired shape. (Fig. 4.2)

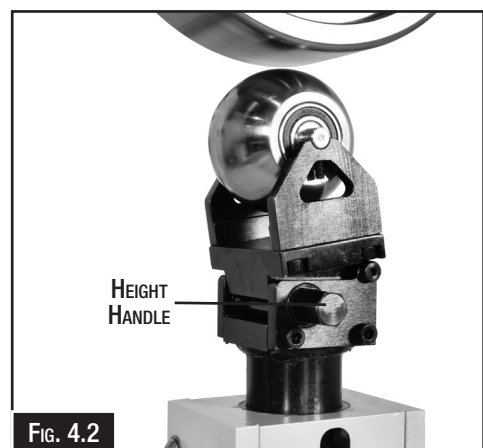

FIG. 4.2

## 4.4 TRACKING PATTERNS

As metal passes between the upper and lower wheels, a “track” or shiny line is pressed into the metal. Various tracking patterns can be used to shape workpieces depending upon their shape or size.

### Zigzag Pattern

This pattern uses closely-spaced tracks to move from one end of the material to the other. It can be used for a variety of workpiece shapes.

1. Insert the workpiece between the wheels at point A, and start rolling it along the edge. Left edge shown.
2. Push the workpiece forward to the stop point.
3. Turn the workpiece counterclockwise slightly. (Fig. 4.3)
4. Pull the workpiece back until it reaches the next point near the far edge.
5. Turn the workpiece clockwise slightly.
6. Continue feeding the workpiece to the other side in the same manner, following the pattern as shown.

**Note:** Try keeping the tracks close to each other.

7. When the wheels reach point B, feed the workpiece in the opposite direction and return to point A. (Fig. 4.4)

### Star Pattern:

The star pattern is useful for shaping round workpieces. (Fig. 4.5)

**Note:** Avoid rolling directly over the center of the workpiece, as too many passes could overstretch the metal.

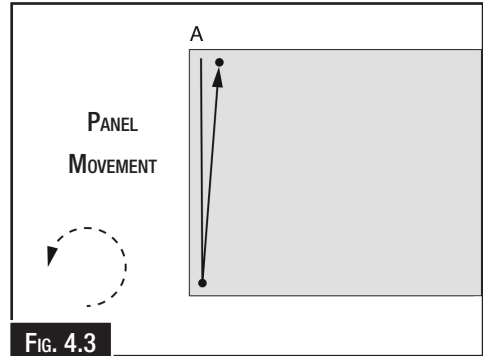

FIG. 4.3

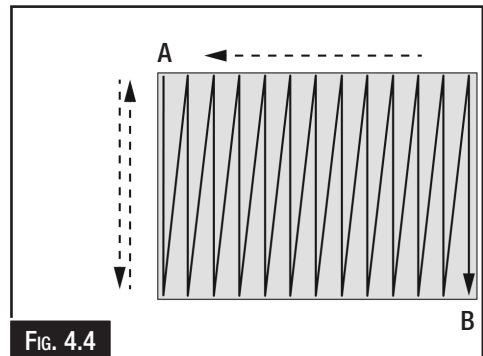

FIG. 4.4

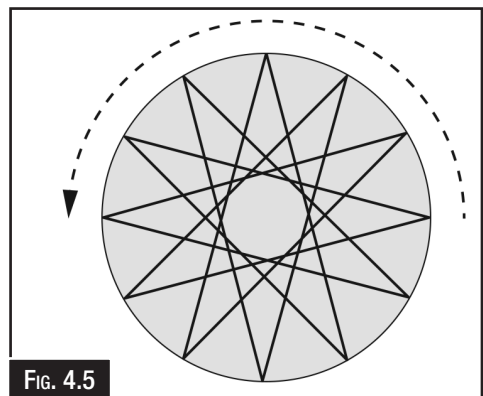

FIG. 4.5



### WARNING!

*Always check the capacity of the machine. Exceeding the capacity of the machine may result in sudden breakage that ejects dangerous metal debris at the operator or bystanders.*



### CAUTION!

*It must be determined by the operator that the materials being processed through the machine are NOT potentially hazardous to operator or personnel working nearby.*

#### 4.4 TRACKING PATTERNS CONT.

##### Staggered Stop Pattern

With this pattern, the track alternates randomly between three different sets of lines.

**Note: Marking the workpiece with a non-permanent marker so you can see the outside, middle and inside lines more clearly.**

Clean the wheels and work piece when you are finished.

1. From the starting point, roll the workpiece from the outside line on one side to the outside line on the opposite side. (Fig. 4.6)
2. Roll the workpiece from the middle line on one side to the middle line on the opposite side.
3. Roll the workpiece from the inside line on one side to the inside line on the opposite side.
4. Repeat Steps 1-3, as you move across the work piece, randomly alternating between outside, middle and inside lines. (Fig. 4.7)

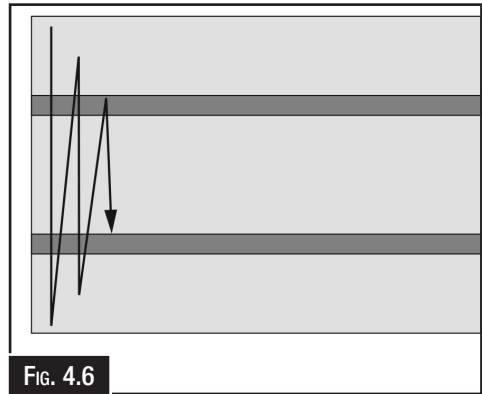

FIG. 4.6

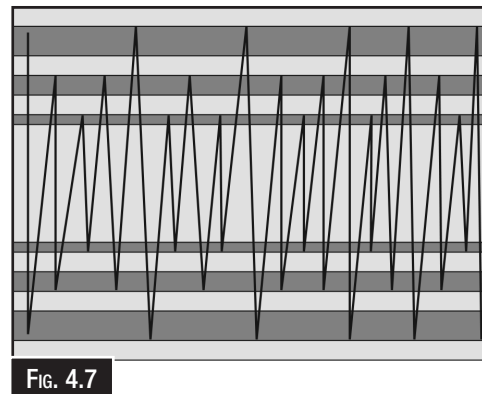

FIG. 4.7

##### Crisscrossing Tracks:

Crisscrossing tracks can help produce smoother curves in your workpiece using the zigzag or staggered stop pattern.

After running tracks along one length of the workpiece, turn the metal sheet 90° and run tracks along the opposite length so the workpiece is equally covered by both sets of tracks. (Fig. 4.8)

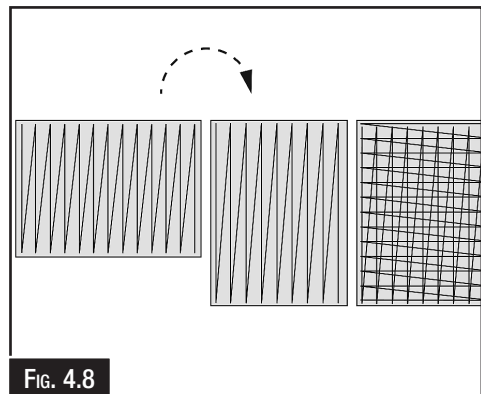

FIG. 4.8



### **WARNING!**

**Before operating any machine, take time to read and understand all safety signs and symbols. If not understood seek explanation from your supervisor or an experienced operator.**

## 5. MAINTENANCE

For optimum performance from a machine, the maintenance schedule should be strictly followed. The suggested schedule for the machine listed in this manual is as follows.

### 5.1 SCHEDULE

#### At All Times:

To minimize your risk of injury and maintain proper machine operation, stop using this machine immediately if you ever observe any of the items below and fix the problem before continuing operations:

- Damaged or dirty wheels.
- Damaged or cracked frame.
- Hardware/fasteners loose or missing
- Any other unsafe condition.

#### Daily Maintenance:

- Clean and protect wheels by smearing with a light machine oil.

#### Monthly Maintenance:

- Clean and lubricate lower wheel saddle stem and adjusting screw. (Fig. 5.1)

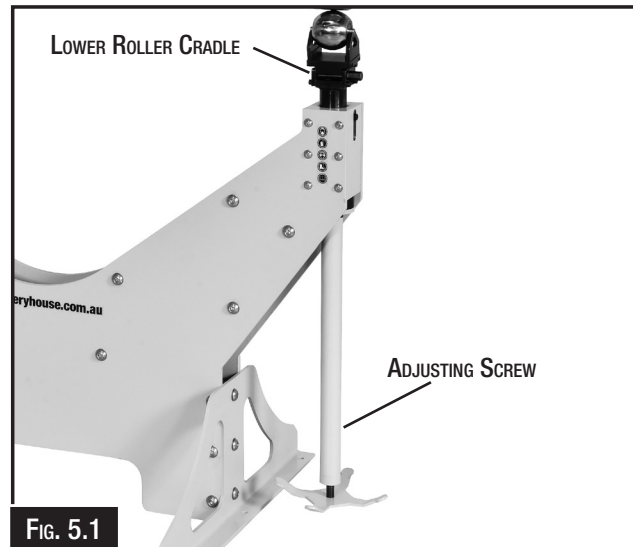

FIG. 5.1

### 5.2 TROUBLESHOOTING

Review the troubleshooting and procedures in this section if a problem develops with your machine. If you need replacement parts then follow the procedure in the beginning of the spare parts section or if additional help with a procedure is required, then contact your distributor.

**Note: Make sure you have the model of the machine, serial number and manufacture date before calling.**

Symptoms	Possible Cause	Possible Solution
Workpiece has wrinkles.	1. Faulty Tracking pattern.. 2. Too much wheel pressure	1. Use a consistent and smooth tracking pattern that overlaps with each back-and-forth pass. 2. Start with least amount of pressure, then gradually increase pressure when curve stops forming
Workpiece surface is marred or scratched.	1. Too much wheel pressure. 2. Wheels are dirty. 3. Wheel is damaged.	1. Reduce wheel pressure. 2. Clean and protect all wheel surfaces (Page 27). 3. Replace wheel
Excessive force needed to move work piece	1. Too much wheel pressure. 2. Wheel bearings at fault.	1. Reduce wheel pressure. 2. Replace wheel bearings
Workpiece curve too high.	1. Lower wheel radius is too small.	1. Use a larger radius (less crown) lower wheel.
Workpiece curve not high enough.	1. Lower wheel radius is too large.	1. Start with lower the largest radius (least curve) wheel and work up to correct radius for operation.
Workpiece curve will not form	1. Not enough wheel pressure. 2. Lower wheel has flat surface.	1. Start with least amount of pressure, then gradually increase pressure when curve stops forming 2. Use lower wheel(s) with a radius (crown).
Wheel does not shape workpiece	1. Workpiece is too thick. 2. Crown is too low; incorrect wheel selection. 3. Incorrect pressure.	1. Use sheet metal of appropriate thickness. 2. Use a lower wheel with a higher crown. 3. Increase pressure on workpiece

## ENGLISH WHEEL EWHD-100

Order Code: (S2256)

Edition : 1.0  
Date: (09/25)

The following section covers the spare parts diagrams and lists that were current at the time this manual was originally printed. Due to continuous improvements of the machine, changes may be made at anytime without notification.

### HOW TO ORDER SPARE PARTS

1. Have your machines model number, serial number & date of manufacture on hand, these can be found on the specification plate mounted on the machine.
2. A scanned copy of your parts list/diagram with required spare part/s identified.

### NOTE: SOME PARTS MAY ONLY BE AVAILABLE AS AN ASSEMBLY

3. Go to [www.machineryhouse.com.au/contactus](http://www.machineryhouse.com.au/contactus) and fill out the inquiry form attaching a copy of scanned parts list.



### **WARNING!**

*Electricity is dangerous and could cause death  
All electrical work must be carried out by a qualified electrician.*



### **CAUTION!**

*It is impossible to cover all possible hazards Every workshop environment is different. These are designed as a guide to be used to compliment training and as a reminder to users prior to equipment use. Always consider safety first, as it applies to the individual working conditions.*

**SPARE PARTS DIAGRAM**

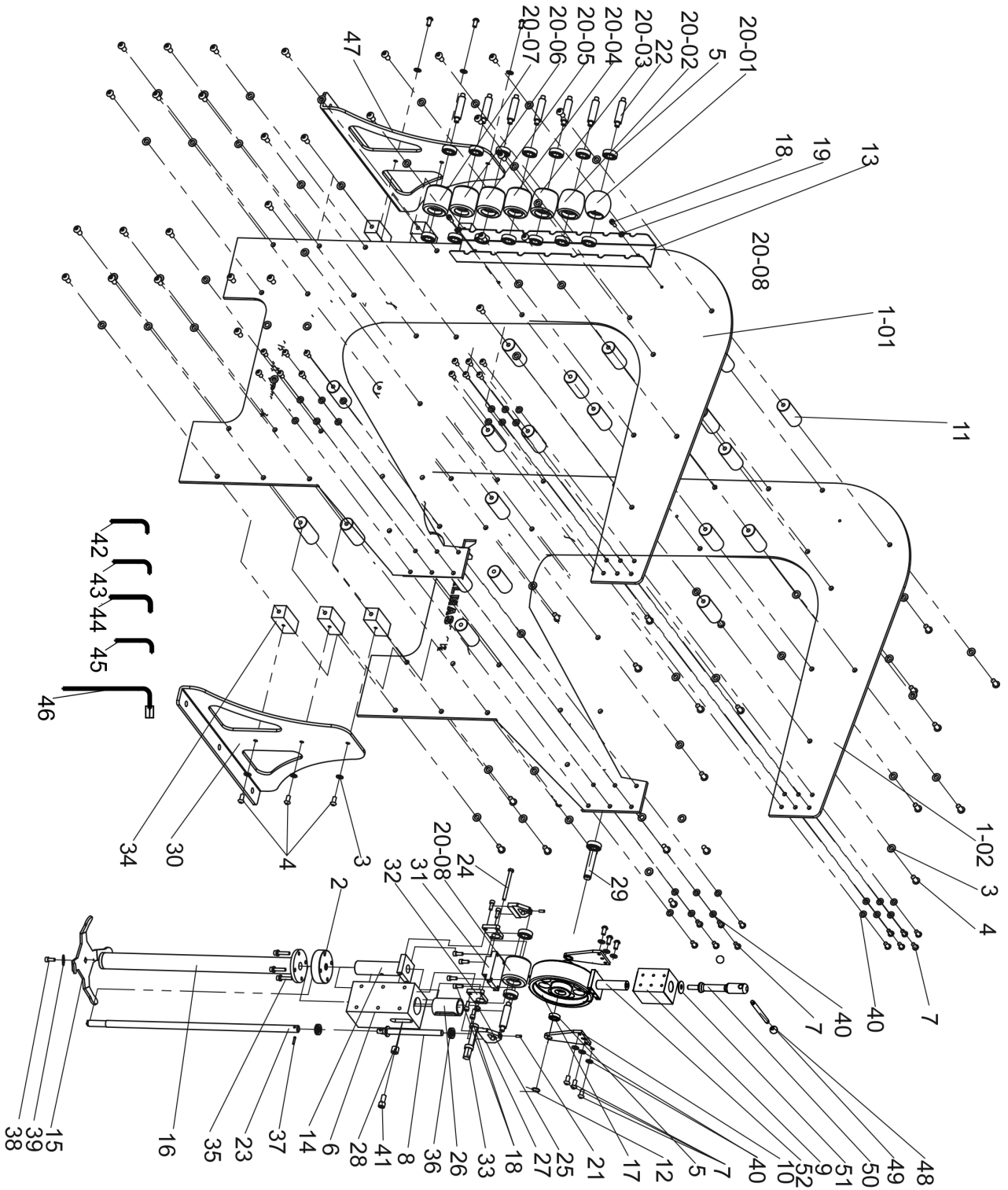

## SPARE PARTS LIST

ITEM	DESCRIPTION	QTY	ITEM	DESCRIPTION	QTY.
1-01	Left Side Plate	1	23	Adjustment Shaft	1
1-02	Right Side Plate	1	24	Bolt	1
2	Round Plate	1	25	Locking Nut M6	1
3	Washer 16mm	60	26	Copper Bushing	1
4	Bolt M16X30	60	27	Lower Wheel Plate	2
5	Bearing 6004-2Z	18	28	Bushing	1
6	Lower Slide Block	1	29	Upper Wheel Shaft	1
7	Screw M10X25	30	30	Front Leg	1
8	Screw	1	31	Lower Wheel Block	1
9	Main Top Block	1	32	Plate	2
10	Upper Wheel Plate	2	33	Eccentric Adjuster	1
11	Plate Spacer	21	34	Square Plate Spacer	6
12	R-Pin	1	35	Screw M8X50	4
13	Lower Wheel Rack	1	36	Bearing 51103	2
14	Guide shaft	1	37	Pin Ø6X20	1
15	Foot Wheel	1	38	Screw M6X10	1
16	Adjusting Tube	1	39	Washer 6mm	1
17	Upper Wheel	1	40	Washer 10mm	30
18	Screw M8X20	10	41	Screw M10X20	1
19	Washer 8mm	2	42	Hex Key Wrench 3mm	1
20-01	2" Lower Wheel	1	43	Hex Key Wrench 5mm	1
20-02	4" Lower Wheel	1	44	Hex Key Wrench 6mm	1
20-03	6" Lower Wheel	1	45	Hex Key Wrench 8mm	1
20-04	8" Lower Wheel	1	46	L Wrench 19mm	1
20-05	12" Lower Wheel	1	47	Rear Leg	1
20-06	24" Lower Wheel	1	48	Handle Ball	2
20-07	36" Lower Wheel	1	49	Handle Lever	1
20-08	48" Lower Wheel	1	50	Screw	1
21	Screw M6X20	2	51	Washer	1
22	Lower Wheel Shaft	8	52	Upper Wheel Rack	1

**NOTE: SOME INDIVIDUAL PARTS MAY ONLY BE AVAILABLE AS AN ASSEMBLY**



#### **ENVIRONMENT PROTECTION**

Recycle unwanted materials instead of disposing of them as waste. All tools, accessories and packaging should be sorted, taken to a recycling centre and disposed of in a manner which is compatible with the environment. When the product becomes completely unserviceable and requires disposal, drain any fluids (if applicable) into approved containers and dispose of the product and fluids according to local regulations.

IMPORTED BY

---

**HARE&FORBES**  
**MACHINERYHOUSE**

Australian Distributor

**Hare & Forbes**  
**Machineryhouse**  
Sydney - Melbourne  
Adelaide - Brisbane - Perth

**Ph: 1300 202 200**  
**[www.machineryhouse.com.au](http://www.machineryhouse.com.au)**

**MACHINERYHOUSE**

New Zealand Distributor

**Machineryhouse**  
Auckland  
Christchurch

**Ph: 0800 142 326**  
**[www.machineryhouse.co.nz](http://www.machineryhouse.co.nz)**